

THIS DRAWING IS UNPUBLISHED. RELEASED FOR PUBLICATION .19
 © COPYRIGHT 19 BY AMP INCORPORATED. ALL RIGHTS RESERVED.

LOC	DIST	REVISIONS					
CE	00	F	LTR	DESCRIPTION	DATE	DWN	APVD
		A		RELEASE TO ACTIVE	08JUN2006	BB	LS
		B		REVISE PER ECR-07-006160	16APR2007	BB	LS

- 1 MATERIAL:
 CONNECTOR ASSY
 REAR BODY: ALUMINUM ALLOY
 PLUNGER: ALUMINUM ALLOY
 FERRULE: CERAMIC
 COUPLING NUT: ZINC, NICKEL PLATED
 INTERNAL COMPONENTS: PEI, COLOR: NATURAL
 SPRING: STAINLESS STEEL
 PROTECTIVE COVER: LDPE, COLOR: BLACK, NON-FR
 PROTECTIVE CAP: VINYL, COLOR: BLACK
 CRIMP EYELET: COPPER, NICKEL PLATED
 INNER EYELET: BRASS
 POLYMER TUBING: TYGON, COLOR: CLEAR
 HYTREL, COLOR: WHITE
 PVC, COLOR: BLACK
 STRAIN RELIEF: POLYOLEFIN ELASTOMER, COLOR: SEE TABLE, NON-FR
 BOOT: POLYOLEFIN ELASTOMER, COLOR: SEE TABLE*
 *UL94 V-0 RATED AT QUALIFYING THICKNESS.

2. THIS KIT WILL TERMINATE:
 900um TIGHT BUFFERED FIBER
 250um COATED FIBER
 2.0-3.0mm JACKETED CABLE
 900um BREAK-OUT KIT
 900um EASY STRIP OR SEMI-TIGHT BUFFERED FIBER

3 PROTECTIVE CAP AND COVER ARE SHOWN REMOVED FROM CONNECTOR ASSEMBLY FOR CLARITY ONLY.

4. TIGHT BUFFER TO BE 900±50um.

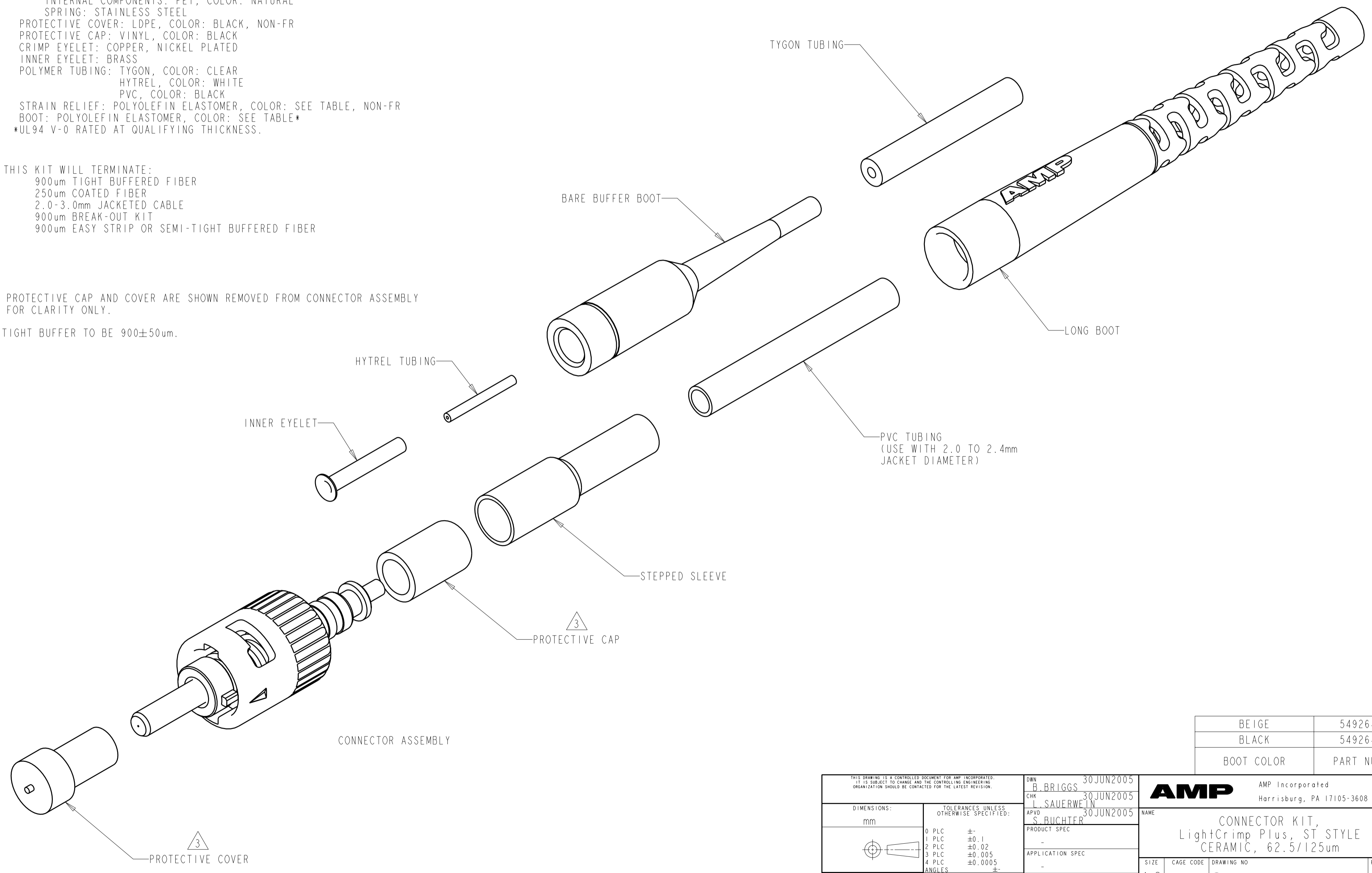

BEIGE	5492642-2
BLACK	5492642-1
BOOT COLOR	PART NUMBER

THIS DRAWING IS A CONTROLLED DOCUMENT FOR AMP INCORPORATED. IT IS SUBJECT TO CHANGE AND THE CONTROLLING ENGINEERING ORGANIZATION SHOULD BE CONTACTED FOR THE LATEST REVISION.		DWN B. BRIGGS 30 JUN 2005	AMP Incorporated Harrisburg, PA 17105-3608	
DIMENSIONS: mm		CHK L. SAUERWEIN 30 JUN 2005	NAME CONNECTOR KIT, LightCrimp Plus, ST STYLE CERAMIC, 62.5/125um	
TOLERANCES UNLESS OTHERWISE SPECIFIED: 0 PLC ±- 1 PLC ±0.1 2 PLC ±0.02 3 PLC ±0.005 4 PLC ±0.0005 ANGLES ±- FINISH -		APVD S. BUCHTER 30 JUN 2005	RESTRICTED TO -	
MATERIAL		PRODUCT SPEC -	SIZE A2	CAGE CODE 00779
DRAWING NO. G-5492642		DRAWING NO. G-5492642		SCALE 4:1
CUSTOMER DRAWING		SHEET 1 OF 1		REV B